







HepcoMotion[®]
HBS

HEPCO BALL SCREW

Contents

Features and Benefits	3	Ball screw and Nut Types	4
Supply options	4		
 HBSS Series - DIN Standard Series	5	 HBSH Series - High Lead Screws	6
 HBSM Series - Miniature Series	7	 BHF Bearing Housing - Fixed End	8
 BEK Bearing Housing - Fixed End	9	 BEF & BHS Bearing Housings - Supported End	10
 Shaft End Machining Details	11		
Rotational & Critical Speed	12	Buckling Load	13
Average Speed and Load	14	Service Life	14
Torque Calculation	14	Ordering Details	15



Introduction

Hepco ball screw offers a competitively priced range of Precision Rolled ball screws, Nuts and Bearings Housings.

The HBSS series is a single nut DIN 69051 flange design, available in two accuracy grades (C5 and C7) with controlled play (A0) and no play (A1) nuts. For preload critical applications, the C5 grade ball screw can be supplied with a lightly preloaded nut (A2).

Complementing the range, are high lead screws (HBSH series) and miniature screws (HBSM series).

For a complete list of the accuracy and preload combinations, please refer to [4](#).

Features and Benefits

- Extensive range of sizes available on a short lead-time
- Range of preload grades
- Ball screw diameters range from Ø6mm to Ø50mm
- Select sizes available with left hand threads
- Optional machined keyway available
- Standard end machining available
- Custom end machining available, upon request



Introduction

Ball screw and Nut Types

The HepcoMotion ball screw range offers three types of nut: DIN 69051 Standard, High Lead and Miniature.

The table below lists the accuracy grades and levels of clearance that are available as standard, at a short lead time*¹:

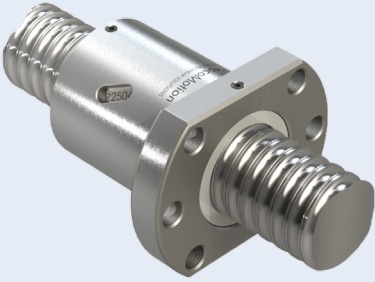
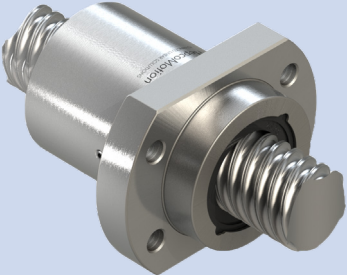
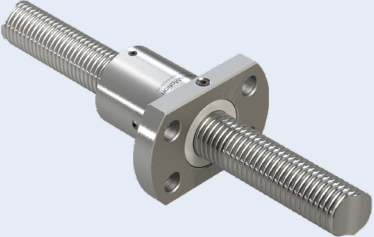
Series	Type	Type	Accuracy Grade	Availability of Preload Grade		
				Light preload	No clearance	Clearance
				A2 grade	A1 grade	A0 grade
HBSS	DIN 69051		C5 (maximum lead deviation of 0.018mm per 300mm of travel)	✓	See note* ²	See note* ²
			C7 (maximum lead deviation of 0.050mm per 300mm of travel)	-	✓	✓
HBSH	High Lead		C5 (maximum lead deviation of 0.018mm per 300mm of travel)	✓	See note* ²	See note* ²
			C7 (maximum lead deviation of 0.050mm per 300mm of travel)	-	✓	✓
HBSM	Miniature		C7 (maximum lead deviation of 0.050mm per 300mm of travel)	-	-	✓

Supply Options

Ball screw units will be supplied with the ends machined and the nut assembled onto the screw. Disassembly of the nut from the screw is not possible without the aid of a special mandrel, in order to prevent the loss of the recirculating balls.

We recommend that units are purchased with the ends ready machined to one of the standard configurations, outlined in this catalogue, using the relevant end support bearing (see [11](#)).

Machining to bespoke drawing requirements is possible. Screws without end machining can also be supplied. However, it should be borne in mind that the nut will be assembled onto the screw, and care will need to be taken when machining, in order to prevent the ingress of dirt into the recirculating system.

Notes:

- Other combinations are not stocked but available on competitive lead times
- Standard accuracy-preload combinations:
 - C5 screw with A2 light preload nut
 - C7 screw with A1 no play nut
 - C7 screw with A0 axial play nut - Max. axial play for Ø16–40mm screws = 0.08mm. Max. axial play for Ø50mm screws = 0.12mm



HBS Series - DIN Standard Series

HepcoMotion HBSS ball screws comply with DIN 69051 and range in diameters from $\varnothing 16\text{mm}$ to $\varnothing 50\text{mm}$. This series is available in C5 or C7 accuracy grades. A selection of sizes are available with a left hand thread*1.

DIN 69051 Form B

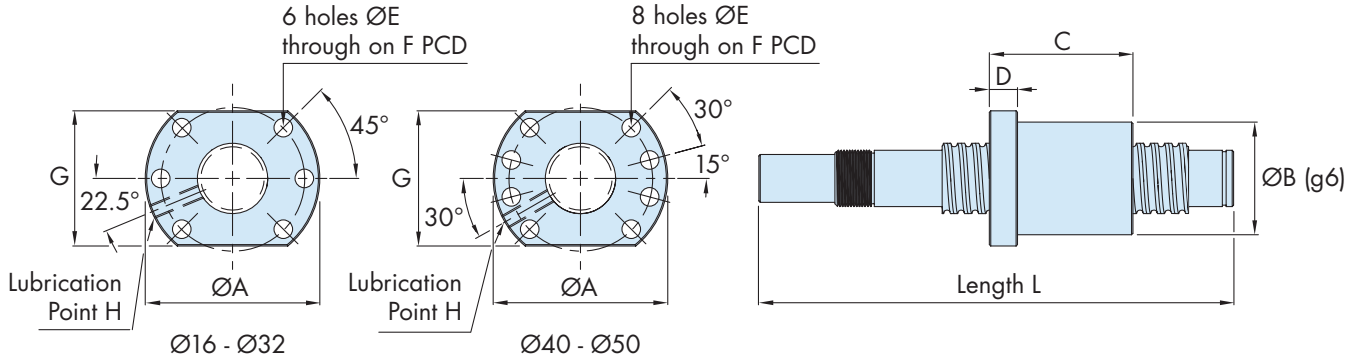

Part Number	L*2 Max	SD Screw \varnothing	Pitch	BCD*3	$\varnothing A$	$\varnothing B$ g6	C	D	$\varnothing E$	F	G	H	N*4 (rpm)	Load Capacity (kN)	
														Ca Basic Dynamic	Coa Basic Static
HBSS 1604 R ...	3000	16	4	16.42	48	28	45	10	5.5	38	40	M6	4260	9.4	12.5
HBSS 1605 R ...	3000	16	5	16.55	48	28	50	10	5.5	38	40	M6	4220	13.4	15.2
HBSS 1605 L ...*1	3000	16	5	16.55	48	28	50	10	5.5	38	40	M6	4220	13.4	15.2
HBSS 1610 R ...	3000	16	10	16.61	48	28	43	12	5.5	38	40	M6	4210	11.8	14.7
HBSS 2005 R ...	3000	20	5	20.59	58	36	53	10	6.6	47	44	M6	3390	15.1	19.9
HBSS 2005 L ...*1	3000	20	5	20.59	58	36	53	10	6.6	47	44	M6	3390	15.1	19.9
HBSS 2010 R ...	3000	20	10	21.03	58	36	68	10	6.6	47	44	M6	3320	16.2	19.2
HBSS 2504 R ...	3500	25	4	25.41	62	40	46	11	6.6	51	48	M6	2750	11.8	20.4
HBSS 2505 R ...	3500	25	5	25.41	62	40	53	10	6.6	51	48	M6	2750	17.0	25.8
HBSS 2505 L ...*1	3500	25	5	25.60	62	40	53	10	6.6	51	48	M6	2730	17.0	25.8
HBSS 2510 R ...	3500	25	10	25.99	62	40	85	12	6.6	51	48	M6	2690	28.8	36.9
HBSS 3205 R ...	3500	32	5	32.58	80	50	53	12	9	65	62	M6	2140	19.2	34.0
HBSS 3205 L ...*1	3500	32	5	32.58	80	50	53	12	9	65	62	M6	2140	19.2	34.0
HBSS 3210 R ...	3500	32	10	33.42	80	50	90	16	9	65	62	M6	2090	48.3	78.3
HBSS 4005 R ...	3500	40	5	40.58	93	63	56	16	9	78	70	M8	1720	21.4	43.4
HBSS 4005 L ...*1	3500	40	5	40.58	93	63	56	16	9	78	70	M8	1720	21.4	43.4
HBSS 4010 R ...	3500	40	10	41.37	93	63	93	18	9	78	70	M8	1690	54.0	100.7
HBSS 5010 R ...	3500	50	10	51.38	110	75	93	18	11	93	85	M8	1360	59.3	123.1

Notes:

1. Nuts marked *1 are supplied with left hand threads. These may be subject to an extended lead time
2. Lengths up to 6000mm are available un-machined for $\varnothing 25-50$ ball screws. These may be subject to an extended lead time
3. Ball center diameter is abbreviated to BCD
4. Characteristic speed, N, is calculated using the formula on page 12



HBSH Series - High Lead Screw

HepcoMotion HBSH ball screws are generally suited to applications that demand linear velocities above 0.5m/s. Please refer to [12](#) for more information on maximum speeds.

The series includes a range of screw diameters from Ø16mm to Ø50mm, and is available in C5 or C7 rolled accuracy grades*^{1,2}.

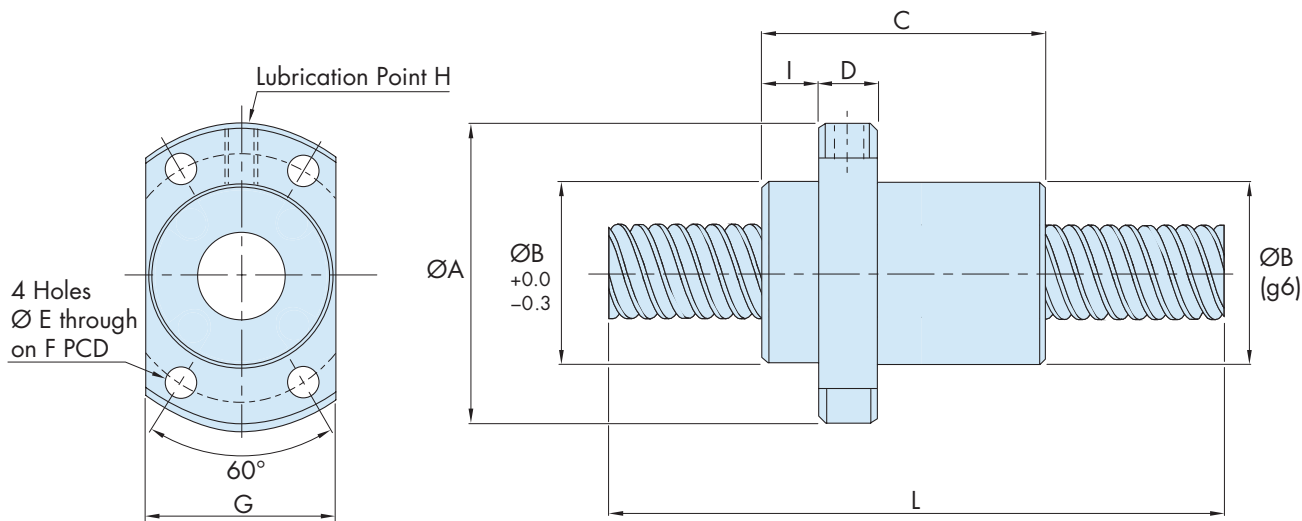

Part Number	L* ³ Max	SD Screw Ø	Pitch	BCD* ⁴	ØA	ØB	C	D	ØE	F	G	H	I	N* ⁵ (rpm)	Load Capacity (kN)	
															Ca Basic Dynamic	Coa Basic Static
HBSH 1616 R ...	3000	16	16	16.61	53	32	48	10	4.5	42	38	M6	10.5	4210	15.1	19.9
HBSH 2020 R ...	3000	20	20	20.61	62	39	55	10	5.5	50	46	M6	10.8	3390	16.6	24.6
HBSH 2525 R ...	3500	25	25	25.73	74	47	67	12	6.6	60	56	M6	11.2	2720	24.8	38.5
HBSH 3232 R ...	3500	32	32	33.04	92	58	82	15	9	74	68	M6	14	2110	35.8	60.7
HBSH 4040 R ...	3500	40	40	41.44	114	73	100	17	11	93	84	M6	17	1680	57.8	117.5
HBSH 5050 R ...	3500	50	50	52.25	135	90	125	20	14	112	92	M6	21.5	1330	88.2	192.4

Notes:

- Standard accuracy-preload combinations:
 - C5 screw with A2 light preload nut
 - C7 screw with A1 no play nut
 - C7 screw with A0 axial play nut - Max. axial play for Ø16-40mm screws = 0.08mm. Max. axial play for Ø50mm screws = 0.12mm
- If the accuracy-preload combination required is not listed, please contact Bishop-Wisecarver
- Lengths up to 6000mm are available un-machined for Ø25-50 ball screws. These may be subject to an extended lead time
- Ball center diameter is abbreviated to BCD
- Characteristic speed, N, is calculated using the formula on page 12



HBSM Series - Miniature Series

HepcoMotion HBSM ball screws offer high positional resolution and a compact design*¹.

The series includes a range of screw diameters from Ø6mm to Ø14mm, and is available in the C7 rolled accuracy grade, as standard*^{2,3}.

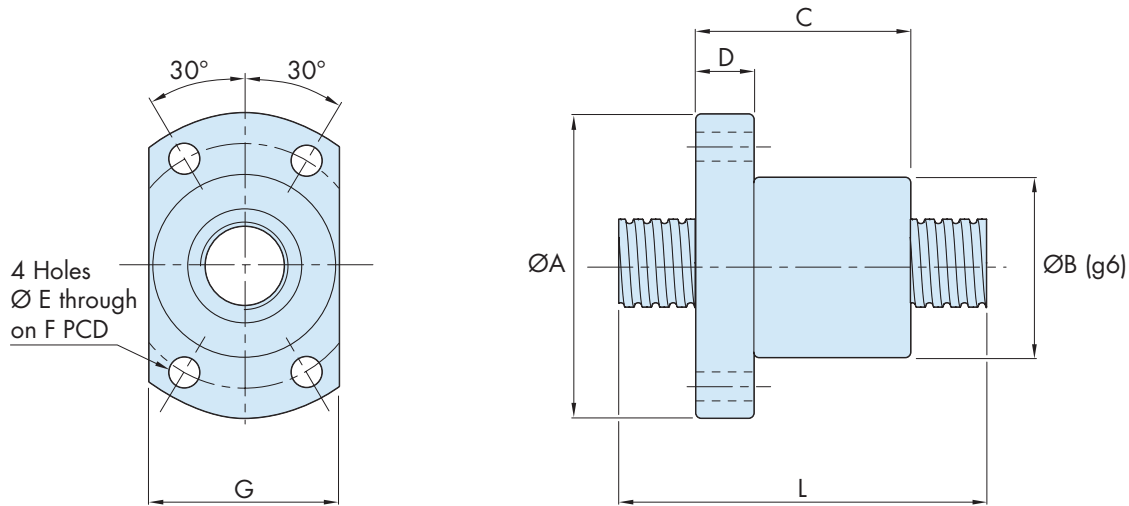

Part Number	L Max	SD Screw Ø	Pitch	BCD* ⁴	ØA	ØB g6	C	D	ØE	F	G	N* ⁵ (rpm)	Load Capacity (kN)	
													Ca Basic Dynamic	Coa Basic Static
HBSM 0601 R ...	900	6	1	6.28	24	12	18	3.5	3.4	18	16	11140	1.11	1.23
HBSM 0801 R ...	3000	8	1	8.23	27	14	20	4	3.4	21	18	8500	1.26	1.62
HBSM 0825 R ...	3000	8	2.5	8.40	29	16	26	4	3.4	23	20	8330	2.15	2.39
HBSM 1002 R ...	3000	10	2	10.42	35	18	28	5	4.5	27	22	6710	2.40	3.02
HBSM 1004 R ...	3000	10	4	10.66	46	26	35	10	4.5	36	28	6560	4.72	4.89
HBSM 1202 R ...	3000	12	2	12.42	37	20	28	5	4.5	29	24	5630	2.65	3.77
HBSM 1205 R ...	3000	12	5	12.34	48	28	35	6	5.5	39	30	5670	5.14	5.94
HBSM 1402 R ...	3000	14	2	14.37	40	21	28	6	5.5	31	26	4870	2.83	4.40

Notes:

1. Please note that HBSM nuts do not have a lubrication port
2. Standard accuracy-preload combination: C7 screw with axial play nut (A0) - Maximum axial play = 0.05mm
3. If the accuracy-preload combination required is not standard, please contact Bishop-Wisecarver
4. Ball center diameter is abbreviated to BCD
5. Characteristic speed, N, is calculated using the formula on page 12

BHF Bearing Housing - Fixed End

HepcoMotion BHF bearing housings are suitable for DIN 69051 standard and high lead ball screws. The housings are made from chemically blackened steel and contain a pair of matched angular contact bearings, to provide accurate radial and axial location for the ball screw.

On installation, the locking nut should be fully tightened and locked in place using the grub screw.

Standard machined 'Fixed Ends' fit into these housings (see Figure A on [11](#)).

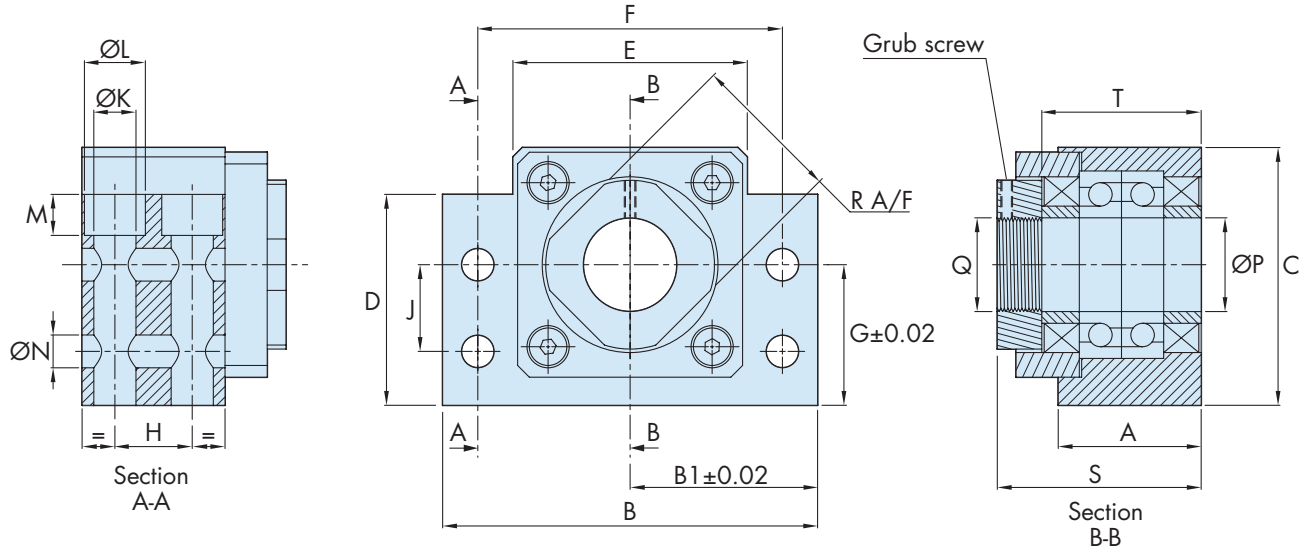

Part Number	Use With Ball Screw Ø	A	B	B1	C	D	E	F	G	H	J	ØK	ØL	M	ØN	ØP	Q	R	S	T
BHF 16	16	25	60	30	43	35	34	46	25	13	18	6.6	10.8	6	5.5	12	M12x1	19	34	26
BHF 20	20	27	70	35	48	38	40	54	28	15	18	6.6	11	6	5.5	15	M15x1	22	38	30
BHF 25	25	35	86	43	64	55	50	68	39	19	28	9	14	8.5	6.6	17	M17x1	24	51	38
BHF 32	32	35	88	44	60	50	52	70	34	19	22	9	14	8.5	6.6	20	M20x1	30	51	40
BHF 40	40	45	128	64	89	78	76	102	51	23	33	14	20	13	11	30	M30x1.5	40	70	50
BHF 50	50	61	160	80	110	90	100	130	60	33	37	18	26	17.5	14	40	M40x1.5	50	91	66

Part Number	Load Capacity (kN)	
	Ca Basic Dynamic	Coa Basic Static
BHF 16	7.60	9.03
BHF 20	7.99	10.5
BHF 25	14.1	18.2

Part Number	Load Capacity (kN)	
	Ca Basic Dynamic	Coa Basic Static
BHF 32	14.1	20.0
BHF 40	29.5	44.8
BHF 50	46.5	76.1

Illustration of Hepco ball screw fitted with Fixed End and Supported End bearing housings:

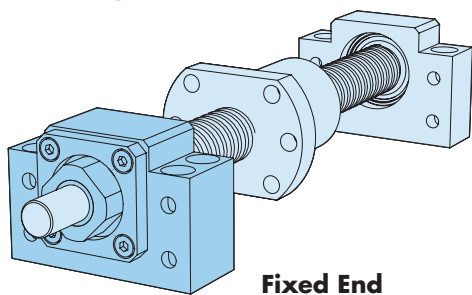

Fixed End

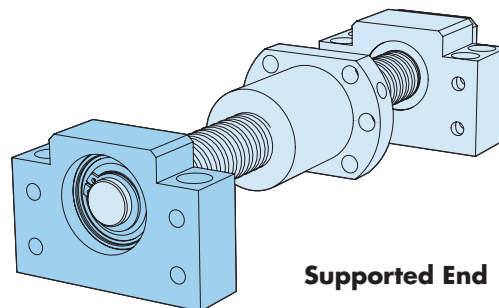

Supported End

BEK Bearing Housing - Fixed End

HepcoMotion BEK bearing housings are suitable for miniature ball screws. The housings are made from chemically blackened steel and contain a pair of matched angular contact bearings, to provide accurate radial and axial location for the ball screw.

On installation, the locking nut should be fully tightened and locked in place using the grub screw.

Standard machined 'Fixed Ends' fit into these housings (see Figure A on [11](#)).

BEK 8 & BEK 10

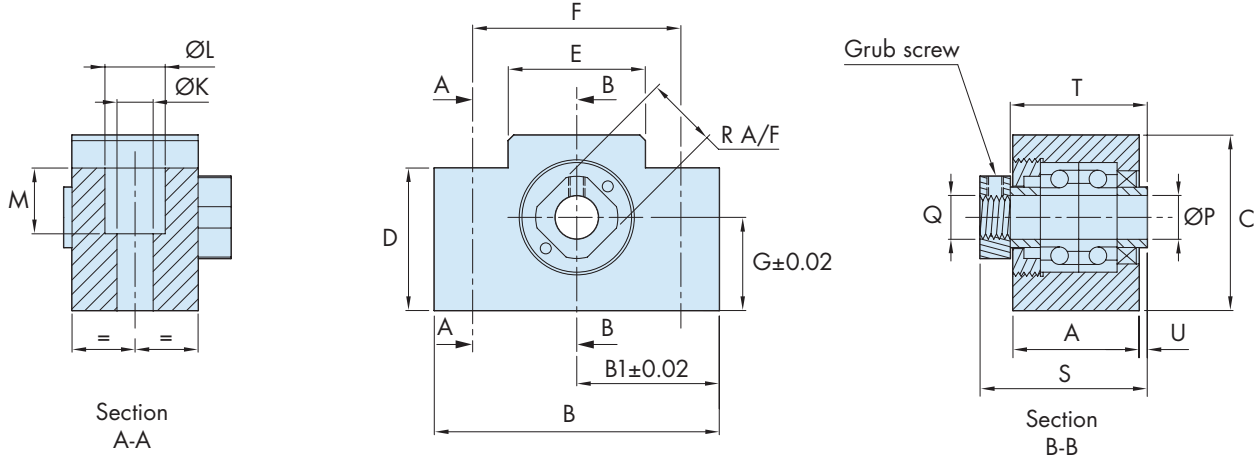

BEK 12 & BEK 14

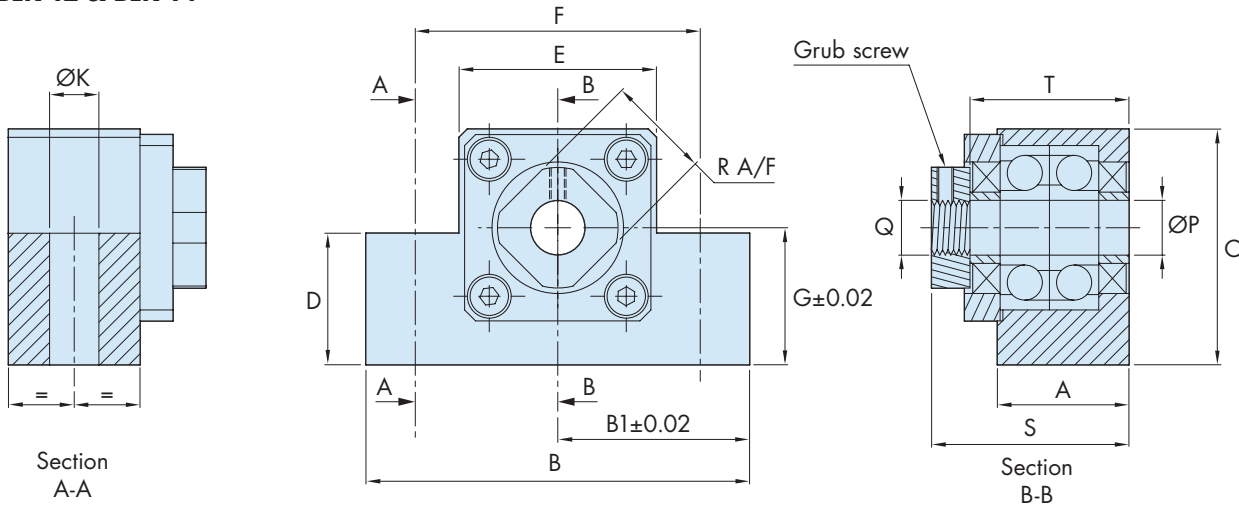

Part Number	Use With Ball Screw Ø	A	B	B1	C	D	E	F	G	ØK	ØL	M	ØP	Q	R	S	T	U	
-	6	Standard bearing housings are not available																	
BEK 8	8	20	42	21	25	20	18	30	13	5.5	9.5	11	6	M6x0.75	12	29	24.5	3.5	
BEK 10	10	23	52	26	32	26	25	38	17	6.6	11	12	8	M8x1	14	34	27.5	3.5	
BEK 12	12	24	70	35	43	24	36	52	25	9	-	-	10	M10x1	16	36	28	-	
BEK 14	14	24	70	35	43	24	36	52	25	9	-	-	12	M12x1	19	36	28	-	

Part Number	Load Capacity (kN)	
	Ca Basic Dynamic	Coa Basic Static
BEK 8	3.67	3.34
BEK 10	2.24	2.60

Part Number	Load Capacity (kN)	
	Ca Basic Dynamic	Coa Basic Static
BEK 12	7.01	7.88
BEK 14	7.60	9.03

BEF & BHS Bearing Housings - Supported End

HepcoMotion BEF and BHS bearing housings are made from chemically blackened steel and have an accurately machined bore, into which a deep groove ball bearing is fitted. The bearing is a sliding fit in the bore and is axially located onto the end of the ball screw using a circlip, which is included with the unit.

Standard machined 'Support Ends' fit into these housings (see Figure B on [11](#)).

BEF 8 – BEF 1214

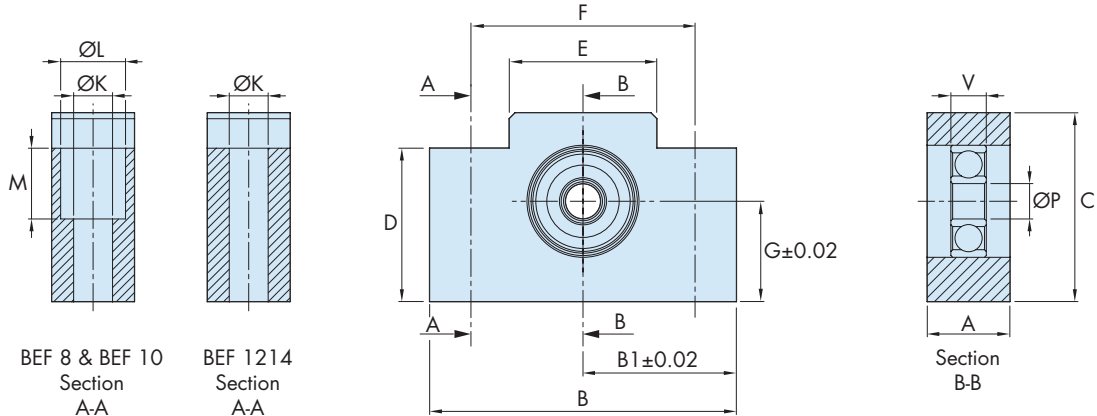

BHS 16 – BHS 50

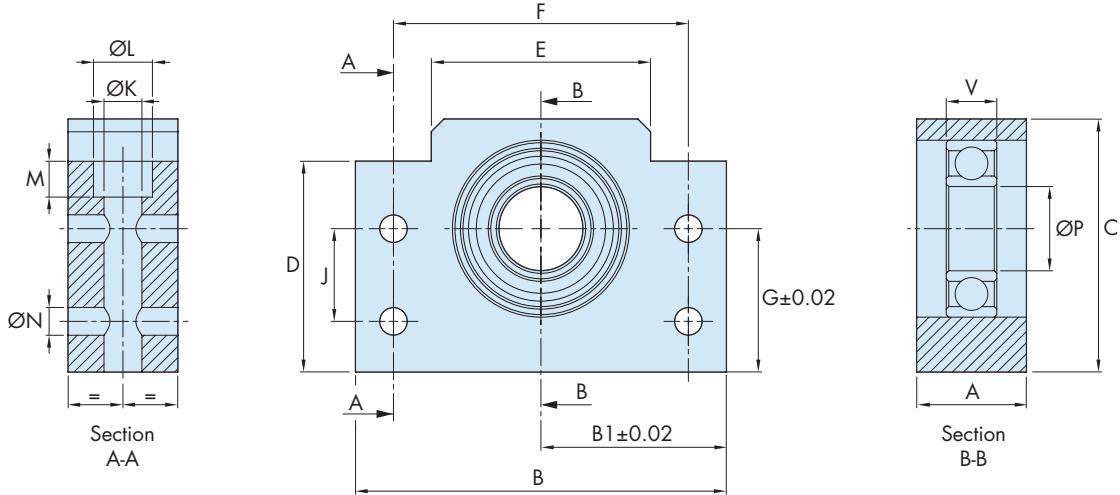

Part Number	Ball Screw Diameter Ø	A	B	B1	C	D	E	F	G	J	ØK	ØL	M	ØN	ØP	V
-	6	Standard bearing housings are not available														
BEF 8	8	12	42	21	25	20	18	30	13	-	5.5	9.5	11	-	6	6
BEF 10	10	14	52	26	32	26	25	38	17	-	6.6	11	12	-	6	6
BEF 1214	12 & 14	20	70	35	43	26	36	52	25	-	9	-	-	-	8	7
BHS 16	16	20	60	30	43	35	34	46	25	18	6.6	10.8	6.5	5.5	10	8
BHS 20	20	20	70	35	48	38	40	54	28	18	6.6	11	6.5	5.5	15	9
BHS 25	25	23	86	43	64	55	50	68	39	28	9	14	8.5	6.6	17	12
BHS 32	32	26	88	44	60	50	52	70	34	22	9	14	8.5	6.6	20	12
BHS 40	40	32	128	64	89	78	76	102	51	33	14	20	13	11	30	16
BHS 50	50	37	160	80	110	90	100	130	60	37	18	26	17.5	14	40	18

Part Number	Load Capacity (kN)	
	Ca Basic Dynamic	Coa Basic Static
BEF 8	2.26	1.67
BEF 10	2.26	1.67
BEF 1214	3.30	2.74

Part Number	Load Capacity (kN)	
	Ca Basic Dynamic	Coa Basic Static
BHS 16	4.55	3.94
BHS 20	5.60	5.70
BHS 25	9.60	9.60

Part Number	Load Capacity (kN)	
	Ca Basic Dynamic	Coa Basic Static
BHS 32	9.40	10.0
BHS 40	19.5	22.6
BHS 50	29.1	35.8

Shaft End Machining Details

The end machining details, shown below, suit Fixed End (BHF/BEK) and Supported End (BEF/BHS) bearing housings.

An optional keyway can be machined to suit DIN6885 parallel keys*2.

Bishop-Wisecarver can machine ends to custom requirements, on receipt of a drawing.

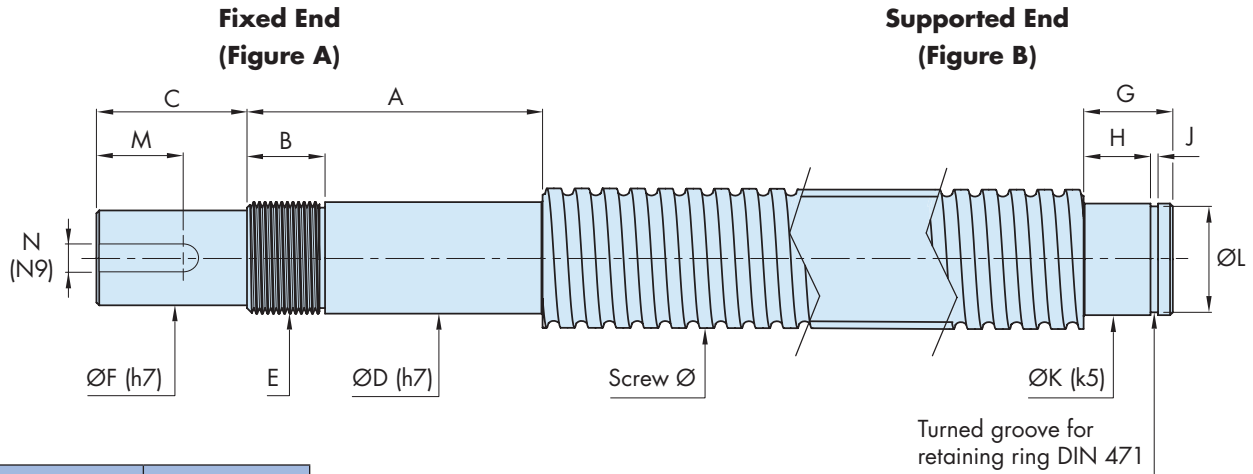

Use With	Ball Screw Diameter Ø	A	B	C	ØD	E	ØF
BEK 8	8	29	9	8	6	M6x0.75	4
BEK 10	10	34	11	10	8	M8x1	6
BEK 12	12	38	13	15	10	M10x1	8
BEK 14	14	38	13	15	12	M12x1	10
BHF 16	16	39	15	19	12	M12x1	10
BHF 20	20	43	15	20	15	M15x1	12
BHF 25	25	56	20	25	17	M17x1	15
BHF 32	32	56	18	35	20	M20x1	17
BHF 40	40	75	28	43	30	M30x1.5	25
BHF 50	50	98	35	50	40	M40x1.5	35

Use With	Ball Screw Diameter Ø	G	H	J	ØK	ØL	M	N
BEF 8	8	9	6	0.8	6	5.7	See note*3	
BEF 10	10	9	6	0.8	6	5.7	5	2
BEF 1214	12	10	7	0.9	8	7.6	7.5	2
	3							
BHS 16	16	11	8	1.15	10	9.6	9.5	3
BHS 20	20	13	9	1.15	15	14.3	10	4
BHS 25	25	16	12	1.15	17	16.2	12.5	5
BHS 32	32	16	12	1.35	20	19	17.5	5
BHS 40	40	21	16	1.75	30	28.6	21.5	8
BHS 50	50	23	18	1.95	40	37.5	25	10

Note:

- There is no standard end machining design for the Ø6 ball screw, as Bishop-Wisecarver does not stock bearing housings for this size. Please submit a drawing showing details of custom end machining requirements
- See [15](#) for ordering details
- Standard keyway machining is not offered for 8mm diameter ball screws. Bishop-Wisecarver can machine ends to custom requirements, on receipt of a drawing

Technical Information and Calculations

Rotational Speed

The speed of a ball screw is generally specified in terms of its linear velocity. The rotational speed is calculated using the following equation:

$$n = \frac{v}{P} \times 10^3$$

n = rotational speed (rpm)
 v = linear velocity (m/min)
 P = pitch (mm)

The rotational speed should not exceed the Critical and Characteristic Speeds, as specified below:

Critical Speed

The critical speed is the speed at which the ball screw will resonate at its natural frequency. It includes a 20% safety factor.

The permissible maximum rotational speed for any size and length of ball screw depends on the diameter of the screw, end fixing and free length L, and can be taken from the chart below. The four scales correspond to the four mounting options.

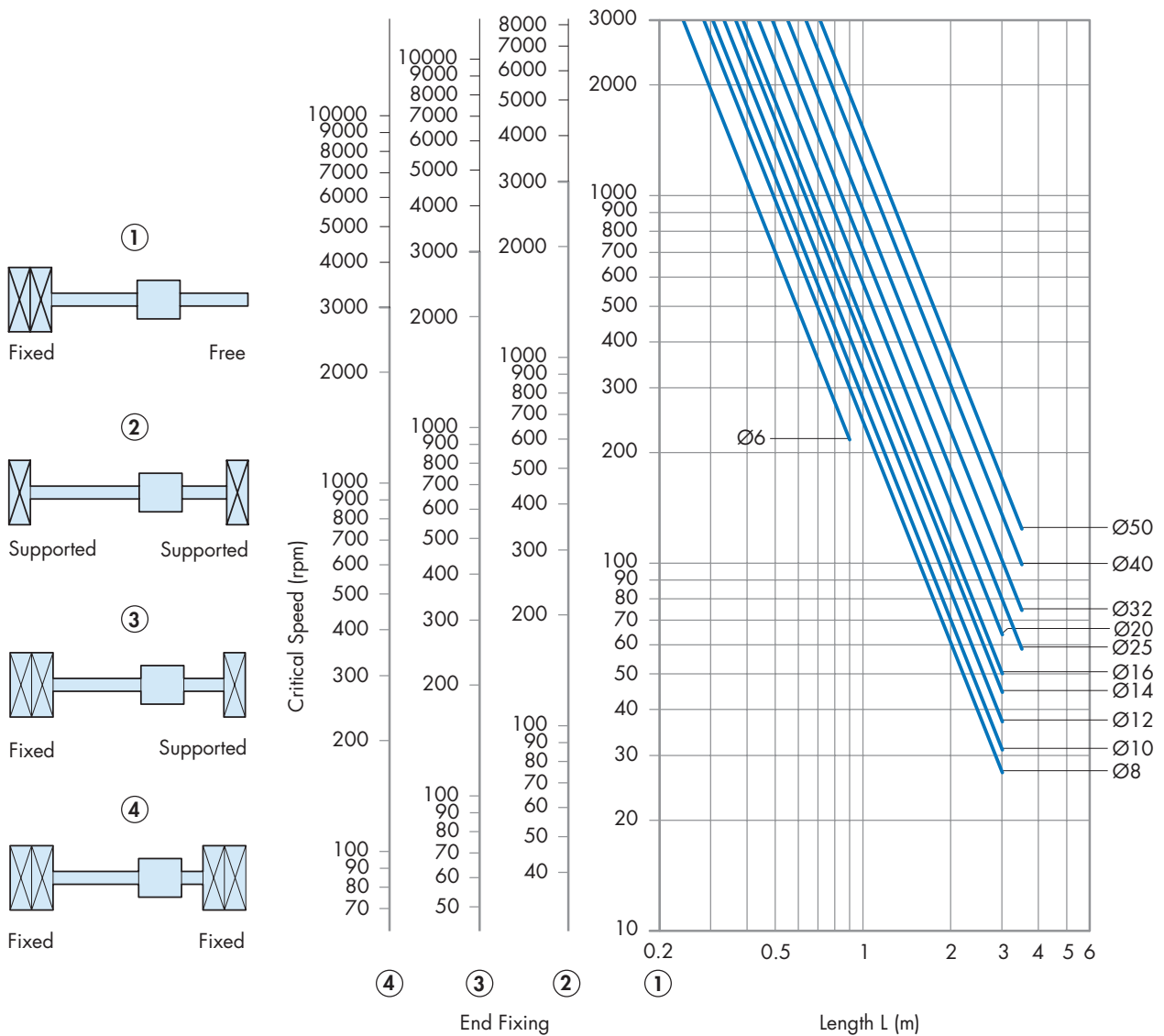

Characteristic Speed

The characteristic speed is the rotational speed limit of the recirculation system in the nut. Exceeding this speed may lead to a reduction in the life of the mechanism. The ball circle diameter, BCD, can be found in the tables of the respective product pages.

$$\text{Characteristic speed, } N \text{ (rpm)} = \frac{70,000}{\text{Ball circle diameter, BCD (mm)}}$$

Buckling Load

The graph below shows the maximum axial compressive load which would cause the ball screw to bend or buckle. This maximum load depends on the diameter of the ball screw, the method of end fixing and free length L. The four scales correspond to the four mounting options. The chart includes a safety factor of 2.

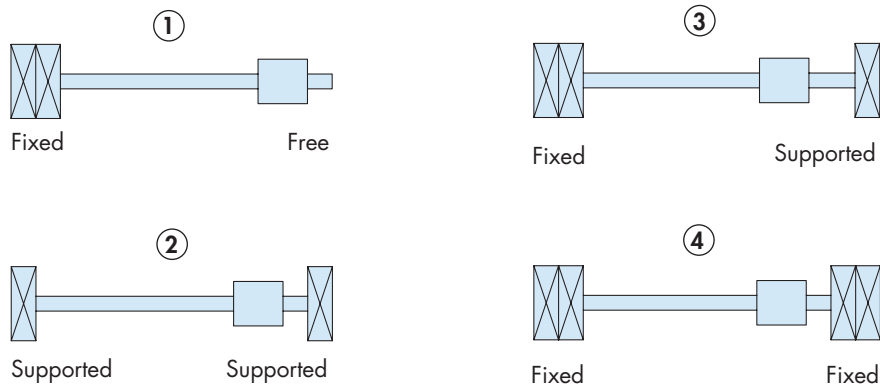
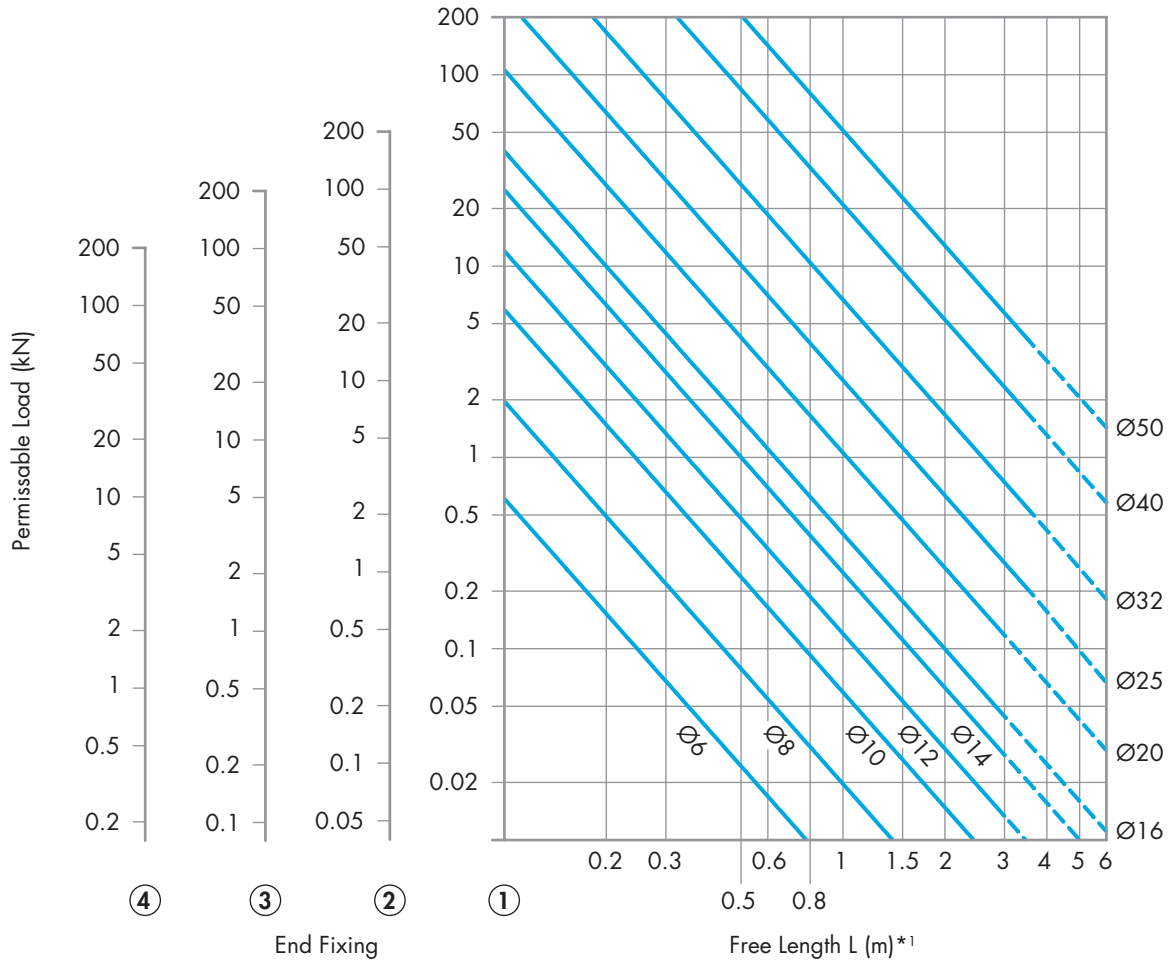

Note:

1. The dashed section of the line indicates where the length exceeds the L max dimension referenced on the respective product pages. Longer lengths are available at extended lead times. Please contact Bishop-Wisecarver's technical department for more information

Technical Information and Calculations

Average Speed and Average Load

Where the speed varies through the machine cycle, average speed is calculated as follows:

$$n_m = \frac{q_1 \times n_1}{100} + \frac{q_2 \times n_2}{100} + \dots + \frac{q_x \times n_x}{100}$$

n_m = average speed (rpm)
 q = time fraction (%)

Where the load varies, the effective load is calculated as follows:

$$F_m = \sqrt[3]{F_1^3 \times \frac{q_1}{100} + F_2^3 \times \frac{q_2}{100} + \dots + F_x^3 \times \frac{q_x}{100}}$$

F_m = average load

Where the load and speed varies, the effective load is calculated as follows:

$$F_m = \sqrt[3]{F_1^3 \times \frac{n_1}{100} \times \frac{q_1}{100} + F_2^3 \times \frac{n_2}{100} \times \frac{q_2}{100} + \dots + F_x^3 \times \frac{n_x}{100} \times \frac{q_x}{100}}$$

Service Life

The basic life is expressed by the number of revolutions that will be attained or exceeded by 90% of a representative sample of identical ball screws before the first signs of material fatigue become evident. Life in hours can be calculated by using the average speed.

$$L_{10} = \left(\frac{C_a}{F_m}\right)^3 \times 10^6$$

L_{10} = service life (revolutions)
 F_m = effective load (kN)
 C_a = dynamic capacity (kN)

$$L_h = \frac{L_{10}}{60n_m}$$

L_h = service life (hours)
 n_m = average speed (rpm)

Torque Calculation

Input torque, for conversion of rotary motion to linear motion:

$$T_{in} = \frac{F \times P}{2000 \times \pi \times \eta}$$

T_{in} = drive torque (Nm)
 F = operating load (N)
 P = lead (mm)
 η = efficiency (approx 0.9)

Output torque, for conversion of linear motion to rotary motion:

$$T_{out} = \frac{F \times P \times \eta'}{2000 \times \pi}$$

T_{out} = transmitted torque (Nm)
 η' = efficiency (approx 0.8)

Ordering Details

Ball screw units will be supplied assembled with ends machined ready for mounting, or assembled with plain ends according to the customer's order. To order separate ball screw or nut components, please see below.

Ordering Details

Nut:

HBSS 16 05 R C7 A0

Part number

Accuracy grade (C...) preload (A...) combination
Standard options: C5 A2*, C7 A1*, or C7 A0

* Option is not available as standard on HBSM type.
Please contact Bishop-Wisecarver, to check availability.

Screw:

HBS 16 05 R C7 1000 (A) L (B) (K)

Screw reference

Diameter (mm)

Pitch (mm)

Thread direction: R for right hand or L for left hand

Accuracy grade: C5 or C7

Overall length (mm)

K - Optional keyway
Leave blank if not required

B - Supported End (Figure B) machining
Leave blank if not required (see [11](#))

Nut orientation: L for left-facing flange,
R for right-facing flange (see diagram below)

A - Fixed End (Figure A) machining
Leave blank if not required (see [11](#))

Fixed End Bearing Housing:

BHF 16

Part number

(Screw diameter in mm)

Supported End Bearing Housing:

BHS 16

Part number

(Screw diameter in mm)

Diagram showing standard end machining and nut orientation designations:

Example 1

Ball screw has standard machining (**A** on left hand end, **B** on right hand end).
Nut flange is left-facing (**L**).

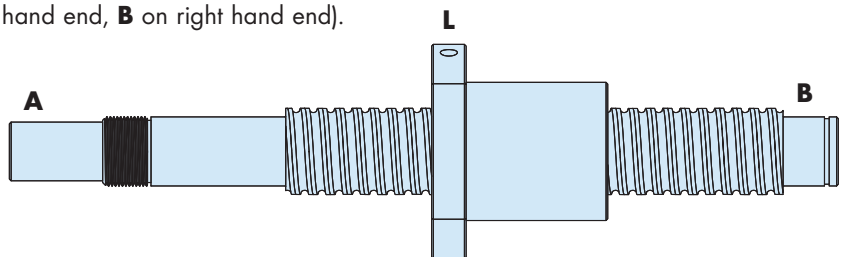

Example 2

Ball screw has standard machining (**A** on left hand end, **B** on right hand end).
Nut flange is right-facing (**R**).

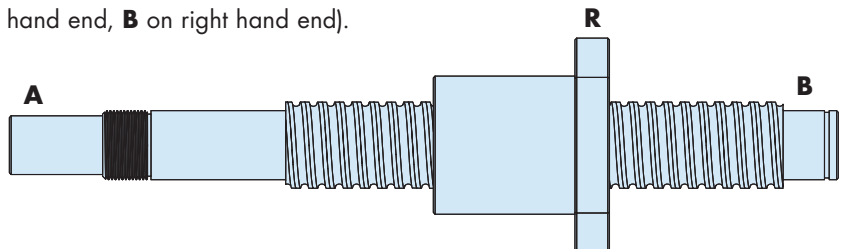

Bishop-Wisecarver® is proud to be the exclusive North American distributor of HepcoMotion® products since 1984.

Components & Accessories

DualVee®
 MadeWell®
 GV3
 SL2
 PRT2
 HDS2
 HDRT
 MCS
 Motor Mounts
 Gantry Brackets
 Wrenches

Manual Linear Guide Systems

DualVee®
 UtiliTrak®
 MinVee®
 GV3
 Simple Select®
 SL2
 HDS2
 MHD
 HTS

Actuated Linear Guide Systems

LoPro®
 XLA™
 ECO60™
 SlickStick™
 SteadyRail™
 HDLS
 HDCS
 PDU2
 DAPDU2
 SBD
 PSD
 SDM
 DLS

Rotary Guide Systems

PRT2
 DTS2
 DTS
 ALR
 HDRT
 1-Trak
 GFX

Robot Transfer Units

LoPro® RTU
 DualVee® RTU

Custom Solutions

Extruded Profile Guides
 Custom Bearings
 Custom Subassemblies
 Engineering Services
 Large Diameter Ring Guides and Track



BWC.COM

Contact

Web: **BWC.com**
 Phone: **(925) 439-8272**
 Email: **Sales@bwc.com**

Corporate Office
 Bishop-Wisecarver
 2104 Martin Way
 Pittsburg, CA 94565

Quality Certifications



- Certified Bay Area Green Business
- Certified Evergreen

Women's Business Enterprise



- Certified WOSB

Certifications & Compliance

- EN 9100:2018
- JISQ 9100:2016
- ISO 13485 & GMP Compliance
- Responsible Minerals Initiative
- RoHS
- International Traffic in Arms Regulations Compliant